

Model TZL16 Powershift Transmission

150 to 180 kW (200 to 245 hp)

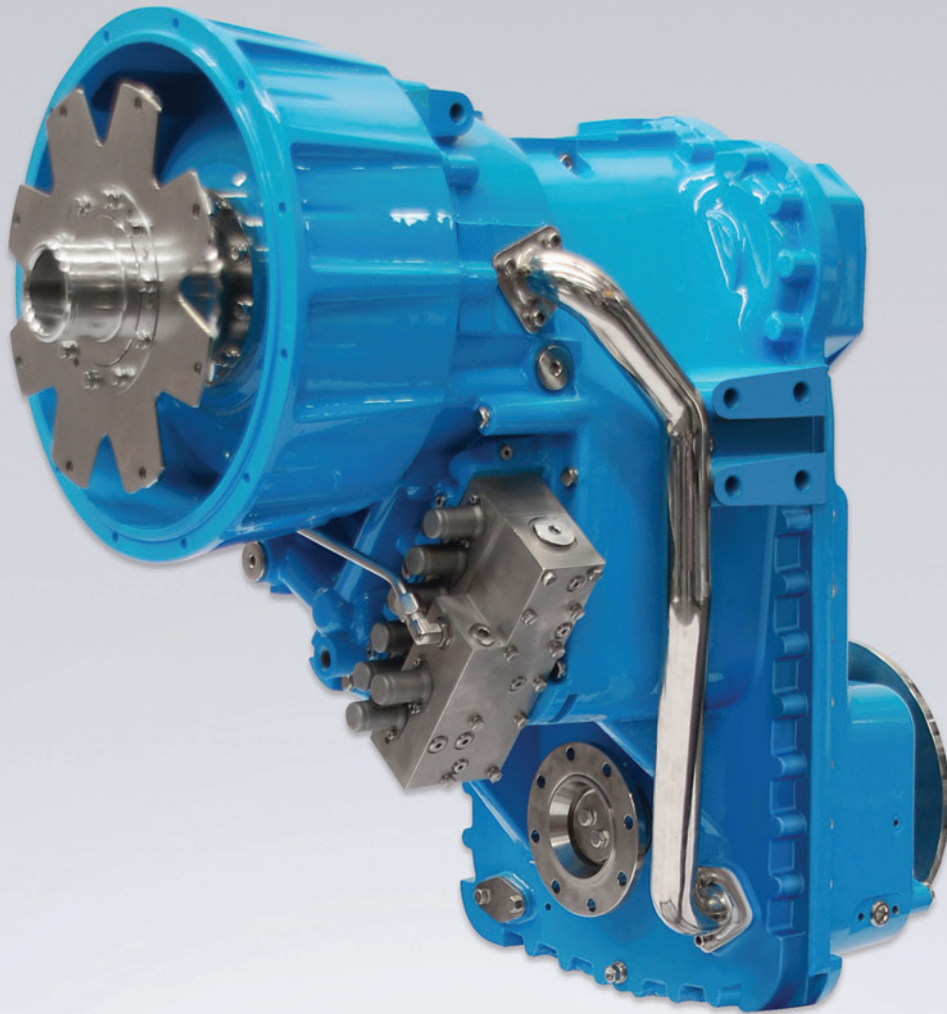

SPICER®
Off-Highway Systems



Engineered to supply front-end loaders with higher input power capability, reduced maintenance, and smoother, quieter operation

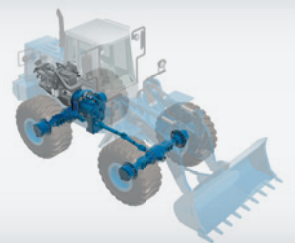

Model TZL16 Powershift Transmission

150 to 180 kW (200 to 245 hp)

The Spicer® TZL16 four-speed transmission platform uses proven internal components from the extensive line of Spicer powershift transmissions already available for the off-highway market. High-energy-capacity forward and reverse clutches, adaptive clutch modulation, and helical gears deliver a robust transmission with improved shift quality.

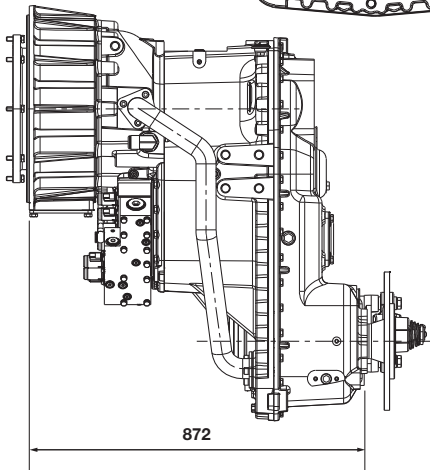
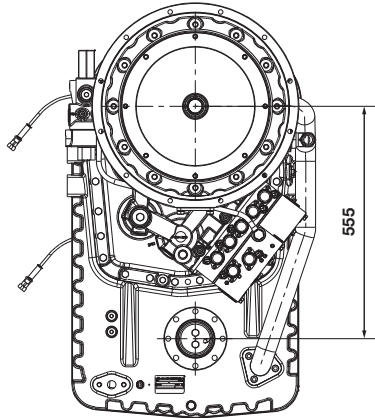

General Rating

Input Power kW (hp)	150 to 180 (200 to 245)
Input RPM Maximum	300
Turbine Stall Nm (ft.-lb.)	1600 (1180)
Total Assembled Weight with SAE 2 Bell Housing Kg (lb)	605 (1333)

FEATURES

- Helical gearing for noise reduction
- Internal plumbing eliminates risk of leaks and external damage
- High capacity clutches ensure longer life
- Adaptive modulation with autoshift allows operators of all levels to shift easily

Converter

Housing	Universal mounting flange for OEM; SAE 2 adaptor flywheel
Wheel Size (T.R.)	340 mm (2.55)
Mounting	HR – integral engine mount

Auxiliary Pump Drive

Offset from Engine Centreline	Left: 123.6 mm Right: 121.5 mm
Torque Capacity Nm	400
Pad Type	2 SAE “C” pumps
Pump Mounting	2- or 4-bolt

Flanges

Spicer	TBD
Mechanics	5C, 6C
GWB	TBD

Ratios (Standard)

	1st Gear	2nd Gear	3rd Gear	4th Gear
4x3	4.351	2.307	1.135	0.653

Dimensions – Oil Capacity

Length Bell Housing Mounting Face to Rear Flange Face	872 mm
Width Maximum	594 mm
Output Drop Vertical	555 mm
Output Offset Horizontal	0 mm
Oil Capacity/Type	Dexron III
Integral Oil Filter	Vertical
Optional Remote Filter (Dipstick Provision)	Vertical

Technical Data

Maximum Input Stall Torque	1600 Nm
Speeds	4 Forward and 3 Reverse
Output Flange Options	DIN – mechanics

Sales Office – Italy
Zona Industriale
Arco, Italy 38062
+1 888 670 3262

www.dana.com/offhighway



SPICER®
Off-Highway Systems

All applications must be approved by the Application Engineering Department. Specifications and/or design are subject to change without notice or obligation.